

## Accessories for CRUSH TESTER – RCT-CCT-ECT-PAT...

Accessories for Crush Test Samples (Paper & Corrugated Board) ECT-RCT-CCT-PAT...

Applicable standards: ISO 13820 – DIN 53134 – DIN EN ISO 3037 – TAPPI T 839 ...

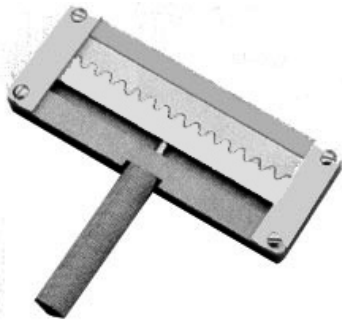

(A) - CCT



(B) - CLT



(C) - ECT (ISO)

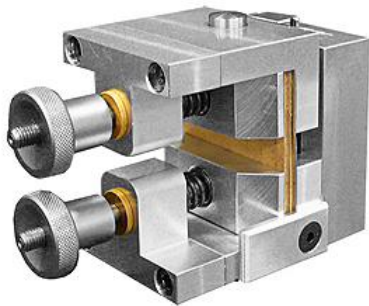

(D) - ECT TAPPI



(E) - RCT



(F) - RCT

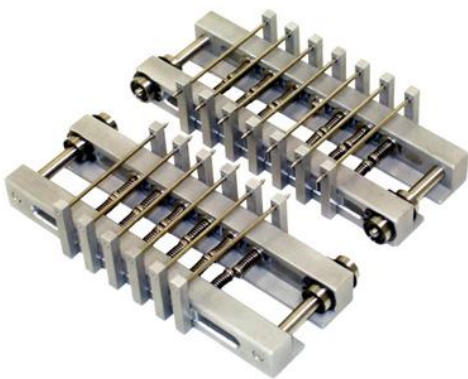

(G) - PAT (variable)

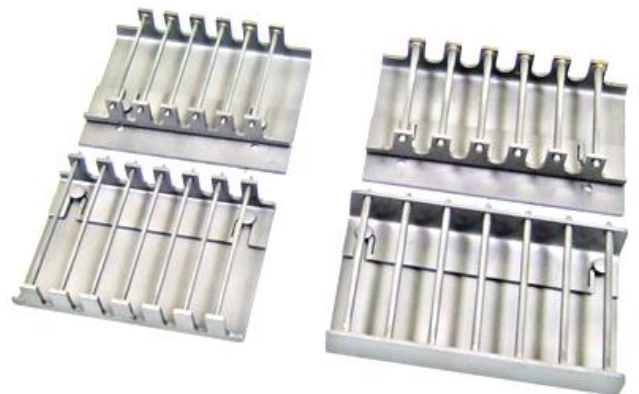

(H-I-J) - PAT (fixed) A/B/C

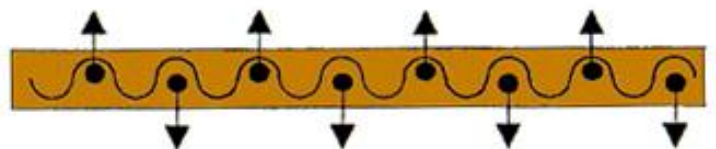
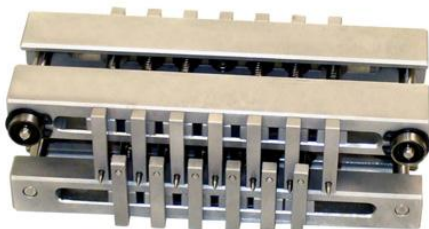

## Accessories for CRUSH TESTER – RCT-CCT-CLT- ECT-PAT...

### For testing paper and corrugated cardboard samples.

Using the Crush Tester, the following tests devices and equipment for sample preparation are needed:

- A - **C.C.T.** Holder (Corrugated Crush Test) Code T-1370  
For sample preparation is required a double blade cutter or punch press (6"X1/2")
- B - **C.L.T.** Holder (Crush Liner Test) Code T-1371  
For sample preparation is required a double blade cutter or punch press (6" X 1/2")
- C - **E.C.T.** Fixture (Edge Crush Test) Code T-1368  
For sample preparation is required a pneumatic sample cutter
- D - **E.C.T. TAPPI T-839** fixture (Edge Crush Test) Code T-6878  
For sample preparation is required a pneumatic sample cutter
- E - **R.C.T.** holder (Ring Crush Test), supplied with 3 rings - discs Code T-1373  
(indicate thickness of the paper to be tested)  
For sample preparation is required a double blade cutter or punch press 6" X 1/2"
- F - **R.C.T. (Resort)** holder (Ring Crush Test) with resort Code T-6799  
For sample preparation is required a double blade cutter or punch press 6" X 1/2"
- G - **P.A.T.** Fixture (Pin Adhesion Test) with sliding pins to be adapted to different sizes of flutes Code T-1367  
(Device for use without standards)  
For sample preparation is required a pneumatic sample cutter
- H - **P.A.T.** holder assembly (Pin Adhesion Test) - Flute **A** (TAPPI T 821) Code T-5332  
For sample preparation is required a pneumatic sample cutter
- I - **P.A.T.** holder assembly (Pin Adhesion Test) - Flute **B** (TAPPI T 821) Code T-6457  
For sample preparation is required a pneumatic sample cutter
- J - **P.A.T.** holder assembly (Pin Adhesion Test) - Flute **C** (TAPPI T 821) Code T-6458  
For sample preparation is required a pneumatic sample cutter

For **C.M.T.** the Medium flutter is needed for sample preparation a double blade cutter or punch press (6" X 1/2")

All tests are made by placing the paper or corrugated cardboard samples in each corresponding device, and placing them between the platens of the samples crush tester.

